

TECHNICAL MANUAL

ORGANIZATIONAL MAINTENANCE REPAIR PARTS AND SPECIAL TOOLS LIST

FOR

TRAINING SET, GUIDED MISSILE

FLIGHT CONTROL (DX-43) (M-22)

(NSN 6920-00-953-9964)

TRAINING SET, GUIDED MISSILE

FLIGHT CONTROL (DX-44) (M-22)

(NSN 6920-00-953-9965)

(M-22 ANTITANK GUIDED MISSILE SYSTEM)

HEADQUARTERS, DEPARTMENT OF THE ARMY

JANUARY 1976

Organizational Maintenance Repair Parts and Special Tools List

FOR

TRAINING SET, GUIDED MISSILE FLIGHT CONTROL (DX-43) (M-22)

(NSN 6920-00-953-9964)

TRAINING SET, GUIDED MISSILE FLIGHT CONTROL (DX-44) (M-22)

(NSN 6920-00-953-9965)

(M-22 ANTITANK GUIDED MISSILE SYSTEM)

Current as of 10 October 1975

Table of Contents

		Page	Illus Figure
Section	I. Introduction	1-1	
	II. Repair parts list.....	2-1	
Group	Training set, guided missile flight control		
0010	(DX-43)(M-22)	2-1	1
0020	Training set, guided missile flight control		
	(DX-44)(M-22)	2-1	2
0031	Stick, control, air	2-2	3
0050	Computer, type CS.6.....	2-2	5
0220	Optical unit	2-2	23
0230	Head, electrical and mechanical, DX-43.....	2-3	24
0240	Base, optical unit, DX-43	2-3	25
0250	Platform, movable, type PS-2	2-3	26
0260	Tripod, type TS1	2-3	27
0280	Cable, electrical	2-3	28
0290	Cable, electrical	2-4	29
0300	Power supply, regulated, GC-24	2-4	30
0330	Projector unit	2-4	32
0340	Support	2-4	33
Section	III. Special tools list (not applicable)		
	IV. Illustrations	4-1	
	V. NSN, Part No. Index	5-1	

*This manual supersedes TM 9-6920-461-20P, 4 May 1973.

Section I. INTRODUCTION

1. Scope.

This manual lists repair parts and other support equipment required for performance of organizational maintenance of the M-22 Antitank Guided Missile System.

2. General.

This Repair Parts and Special Tools List is divided into the following sections:

a. Section II. Repair Parts List. A list of repair parts authorized for use in the performance of maintenance. The list also includes parts which must be removed for replacement of the authorized parts. Parts lists are composed of functional groups in ascending numerical sequence, with the parts in each group listed in figure and item number sequence.

b. Section III. Special Tools List. Not applicable.

c. Section IV. Illustrations. A series of exploded views of assemblies and subassemblies arranged in functional group and figure number sequence. All exploded parts are identified with callout numbers placed in clockwise sequence. These exploded views reflect repair parts plus those parts which must be removed in the process of disassembly for replacement or repair of the authorized item.

d. Section V. National Stock Number and Part Number Index. A list in ascending numerical National Item Identification Number (NIIN) sequence, of all National stock numbers appearing in the listings, followed by a list, in alphameric sequence, of all part numbers appearing in the listings. National stock number and part numbers are cross-referenced to each illustration figure and item number appearance.

3. Explanation of Columns.

The following provides an explanation of columns found in the tabular listings:

a. Illustration. This column is divided as follows:

(1) *Figure Number.* Indicates the figure number of the illustration in which the item is shown.

(2) *Item Number.* The number used to identify each item called out in the illustration.

b. Source, Maintenance, and Recoverability Codes (SMR).

(1) *Source Code.* Source codes are assigned to support items to indicate the manner of acquiring support items for maintenance, repair, or overhaul of end items. Source codes are entered in the first and second positions of the SMR Code format as follows:

<i>Code</i>	<i>Definition</i>
PA	Item procured and stocked for anticipated or known usage.
PB	Item procured and stocked for insurance purpose because essentiality dictates that a minimum quantity be available in the supply systems.
PC	Item procured and stocked and which otherwise would be coded PA except that it is deteriorative in nature.
PD	Support item, excluding support equipment, procured for initial issue or outfitting and stocked only for subsequent or additional initial issues or outfittings. Not subject to automatic replenishment.
PE	Support equipment procured and stocked for initial issue or outfitting to specified maintenance repair activities.
PF	Support equipment which will not be stocked but which will be centrally procured on demand.
PG	Item procured and stocked to provide for sustained support for the life of the equipment. It is applied to an item peculiar to the equipment which, because of probable discontinuance or shutdown of production facilities, would prove uneconomical to reproduce at a later time.
KD	An item of a depot overhaul/repair kit and not purchased separately. Depot kit defined as a kit that provides items required at the time of overhaul or repair.
KF	An item of a maintenance kit and not purchased separately. Maintenance kit defined as a kit that provides an item that can be replaced at organizational or intermediate levels of maintenance.
KB	Item included in both a depot overhaul/repair kit and a maintenance kit.
MO	Item to be manufactured or fabricated at organizational level.
MF	Item to be manufactured or fabricated at the direct support maintenance level.
MH	Item to be manufactured or fabricated at the general support maintenance level.
MD	Item to be manufactured or fabricated at the depot maintenance level.
AO	Item to be assembled at organizational level.
AF	Item to be assembled at direct support maintenance level.
AH	Item to be assembled at general support maintenance level.
AD	Item to be assembled at depot maintenance level.
XA	Item is not procured or stocked because the requirements for the item will result in the replacement of the next higher assembly.
XB	Item is not procured or stocked. If not available through salvage, requisition.
XD	A support item that is not stocked. When required, item will be procured through normal supply channels.

NOTE

Cannibalization or salvage may be used as a source of supply for any items source coded above except those coded XA, XD, and aircraft support items as restricted by AR 700-42.

(2) *Maintenance Code.* Maintenance codes are assigned to indicate the levels of maintenance authorized to USE and REPAIR support items. The maintenance codes are entered in the third and fourth positions of the Uniform SMR Code format as follows:

(a) The maintenance code entered in the third position will indicate the lowest maintenance level authorized to remove, replace, and use the support item. The maintenance code entered in the third position will indicate one of the following levels of maintenance:

<i>Code</i>	<i>Application/Explanation</i>
C	Crew or operator maintenance performed within organizational maintenance.
O	Support item is removed, replaced, used at the organizational level.
F	Support item is removed, replaced, used at the direct support level.
H	Support item is removed, replaced, used at the general support level.
D	Support items that are removed, replaced, used at depot, mobile depot, specialized repair activity only.

(b) The maintenance code entered in the fourth position indicates whether the item is to be repaired and identifies the lowest maintenance level with the capability to perform complete repair (i.e., all authorized maintenance functions). This position will contain one of the following maintenance codes:

<i>Code</i>	<i>Application/Explanation</i>
O	The lowest maintenance level capable of complete repair of the support item is the organizational level.
F	The lowest maintenance level capable of complete repair of the support item is the direct support level.
H	The lowest maintenance level capable of complete repair of the support item is the general support level.
D	The lowest maintenance level capable of complete repair of the support item is the depot level, performed by depot.
L	Repair restricted to designated specialized repair activity.
Z	Nonreparable. No repair is authorized.
B	No repair is authorized. The item may be reconditioned by adjusting, lubricating, etc., at the user level. No parts or special tools are procured for the maintenance of this item.

(3) *Recoverability Code.* Recoverability codes are assigned to support items to indicate the disposition action on unserviceable items. The recoverability code is entered in the fifth position of the Uniform SMR Code format as follows:

<i>Recoverability Codes</i>	<i>Definition</i>
Z	Nonreparable item. When unserviceable, condemn and dispose at the level indicated in position 3.
O	Reparable item. When uneconomically repairable, condemn and dispose at organizational level.

Recoverability

Codes

Definition

F	Reparable item. When uneconomically repairable, condemn and dispose at the direct support level.
H	Reparable item. When uneconomically repairable, condemn and dispose at the general support level.
D	Reparable item. When beyond lower level repair capability, return to depot. Condemnation and disposal not authorized below depot level.
L	Reparable item. Repair, condemnation, and disposal not authorized below depot/specialized repair activity level.
A	Item requires special handling or condemnation procedures because of specific reasons (i.e., precious metal content, high dollar value, critical material or hazardous material). Refer to appropriate manuals/directives for specific instructions.

c. *National Stock Number.* Indicates the National stock number assigned to the item and will be used for requisitioning purposes.

d. *Part Number.* Indicates the primary number used by the manufacturer (individual, company, firm, corporation, or Government activity), which controls the design and characteristics of the item by means of its engineering drawings, specifications standards, and inspection requirements, to identify an item or range of items.

NOTE

When a stock numbered item is requisitioned, the repair part received may have a different part number than the part being replaced.

e. *Federal Supply Code for Manufacturer (FSCM).* The FSCM is a 5-digit numeric code listed in SB 708-42 which is used to identify the manufacturer, distributor, or Government agency, etc.

f. *Description.* Indicates the Federal item name and, if required, a minimum description to identify the item.

g. *Unit of Measure (U/M).* Indicates the standard of the basic quantity of the listed item as used in performing the actual maintenance function. This measure is expressed by a two-character alphabetical abbreviation (e.g., ea, in., pr, etc.). When the unit of measure differs from the unit of issue, the lowest unit of issue that will satisfy the required units of measure will be requisitioned.

h. *Quantity Incorporated in Unit.* Indicates the quantity of the item used in the breakout shown on the illustration figure, which is prepared for a functional group, subfunctional group, or an assembly. A "V" appearing in this column in lieu of a quantity indicates that no specific quantity is applicable (e.g., shims, spacers, etc.).

4. Special Information.

a. Usable on codes are shown in the description column. Uncoded items are applicable to all models. Identification of the usable on codes used in this publication are:

<i>Code</i>	<i>Used On</i>
BVL	DX-43 Training Set
BVM	DX-44 Training Set

b. The following publications pertain to DX-43 and DX-44 Guided Missile Flight Control Training Sets and their components:

- TM 9-6920-461-12
- TM 9-6920-461-35
- TM 9-6920-461-34P

c. The illustrations in this manual are identical to those published in TM 9-6920-461-34P. Only those parts assigned the third position SMR maintenance code "C" or "O" are listed in the tabular listing; therefore, there may be a break in the item number sequence. Only illustrations containing organizational authorized items appear in this manual.

5. How to Locate Repair Parts.

a. When National stock number or part number is unknown:

(1) *First.* Using the table of contents, determine the functional group within which the repair part belongs. This is necessary since illustrations are prepared for functional groups, and listings are divided into the same groups.

(2) *Second.* Find the illustration covering the functional group to which the repair part belongs.

(3) *Third.* Identify the repair part on the illustration and note the illustration figure and item number of the repair part.

(4) *Fourth.* Using the Repair Parts Listing, find the figure and item number noted on the illustration.

b. When National stock number or part number is known.

(1) *First.* Using the Index of National Stock Numbers and Part Numbers, find the pertinent National stock number or part number. This index is in ascending NIIN sequence followed by a list of part numbers in ascending alphabetic sequence, cross-referenced to the illustration figure number and item number.

(2) *Second.* After finding the figure and item number, locate the figure and item number in the repair parts list.

6. Abbreviations.

<i>Abbreviations</i>	<i>Explanation</i>
AMP	ampere(s)
BR	bright
COND	conductor(s)
CUP-PT	cup point

<i>Abbreviations</i>	<i>Explanation</i>
DIA	diameter
EA	each
FLGD	flanged
HEX-SOCKET	hexagon socket
ID	inside diameter(s) (dimension)
INS	insulated, insulating, insulator
LG	long (length)
M	meter(s)
MM	millimeter(s)
OD	olive drab, outside diameter (dimension)
S	steel
SP	single-pole, spool
STGHT	straight
THK	thick(ness)
TUN-FIL	tungsten filament
V	volt(s)
W	watt(s), wide, width
W/	with
X	by (as in 2 x 4)

7. Recommendations for Maintenance Publications Improvements.

You can improve this manual by recommending improvements using DA Form 2028 (Recommended Changes to Publications and Blank Forms) or DA Form 2028-2 (Test) located in the back of the manual and mail the form direct to Commander, U. S. Army Missile Command, ATTN: AMSMI-NPS, Redstone Arsenal, Alabama 35809. A reply will be furnished direct to you.

SECTION II

REPAIR PARTS LIST

TM 9-6920-461-20P

(1) ILLUSTRATION		(2)	(3)	(4)	(5)	(6) DESCRIPTION	(7)	(8) QTY INC IN UNIT
(a) FIG NO.	(b) ITEM NO.	SMR CODE	FEDERAL STOCK NUMBER	PART NUMBER	FSCM	UOC	U/M	
1	1	PAODL	6920-00-963-8475	10-000	19166	GROUP 0010 TRAINING SET, GUIDED MISSILE FLIGHT CONTROL ((DX-43) (M-22) 10173200 (18876)		
1	2	PAOZZ	6920-00-960-8457	507	19166	OPTICAL SET, GUIDED MISSILE FLIGHT CONTROL, TRAINING BVL	EA	1
1	6	PAOHD	6920-00-960-8467	13-400	19166	GLASS, TINTED (GD 5071) BVL	EA	1
1	7	PAOHD	6920-00-960-8438	-13-100	19166	PLATFORM, MOVABLE, TYPE PS-2 (774.227) (FOR PARTS SEE FG 0250) BVL	EA	1
1	8	PAOHH	6920-30-963-8459	336	19166	TRIPOD, TYPE TS1 (774.239) (FOR PARTS SEE FG 0260) BVL	EA	1
1	9	PAODL	6920-00-960-8454	0173194	18876	CABLE, ELECTRICAL 19 COND, 4 M LG (774.233) (FOR PARTS SEE FG 0215) BVL	EA	1
1	10	PAOHD	6920-33-960-8468	774-228	09095	COMPUTER SET, GUIDED MISSILE FLIGHT CONTROL, TRAINING BVL	EA	1
1	11	PAOHH	6920-00-960-8469	10173162	18876	COMPUTER, TYPE CS.6 (774.228) (FOR PARTS SEE FG 0050) BVL	EA	1
1	12	PAODL	6920-00-960-8455	1160	19166	CABLE, ELECTRICAL 3 COND, 10 M LG BVL	EA	1
1	13	PAOHH	6920-00-960-8442	1165	19166	POWER SUPPLY SET, GM FLIGHT CONTROL, TRAINING BVL	EA	1
1	14	PAOHH	6920-00-960-8441	338	19166	POWER SUPPLY, REGULATED, GC-24 (FOR PARTS SEE FG 0300) BVL	EA	1
1	15	PAOHH	6920-00-960-8440	940	19166	CABLE, ELECTRICAL 3 COND, 4 M LG (774.2371 (FOR PARTS SEE FG 0280) BVL	EA	1
1	16	PAOHH	6920-00-960-8453	10173189	18876	CABLE, ELECTRICAL 3 COND, 5 N LG (GD 940) (FOR PARTS SEE FG 0290) BVL	EA	1
1	17	PAOHD	6920-30-960-8439	810-149	09095	ADAPTION KIT, GM FLIGHT CONTROL, TRAINING (M-22) BVL	EA	1
1	18	PAOHH	1430-00-867-9102	10021921	18876	STICK CONTROL, AIR w/ADAPTER 810.134 (FOR PARTS SEE FG 00311) BVL	EA	1
2	1	PADDL	6920-00-960-8454	10173194	188761	CABLE, ELECTRICAL 7 COND, 4 H LG (714.761) BVL GROUP 0020 TRAINING SET, GUIDED MISSILE FLIGHT CONTROL (DX-443 (M-221) 10173201 (18876)		
2	2	PAODH	6920-00-960-8469	774-228	09095	COMPUTER SET, GUIDED MISSILE FLIGHT CONTROL, TRAINING BVM	EA	1
2	3	PAOHH	6920-00-960-8469	10173162	18876	COMPUTER, TYPE CS.6 (774.228) (FOR PARTS SEE FG 0050) BVM	EA	1
2	4	PAOHH	6920-03-960-8453	10173189	18876	CABLE, ELECTRICAL 3 COND, 10 LG BVM	EA	1
2	5	PAOHD	6920-00-960-8439	810-149 0	09095	ADAPTION KIT, GM FLIGHT CONTROL, TRAINING (M-22) BVM	EA	1
2	6	PAOHH	1430-00-887-9102	10021921	18876	STICK, CONTROL, AIR W/ADAPTER 810.134 (FOR PARTS SEE FG 0331) BVM	EA	1
2	7	PAOHH	6920-00-960-8481	20010	19166	CABLE, ELECTRICAL 7 COND, 4 M LG (714.61) BVM	EA	1
2	9	PAOHH	6920-S0-960-8440	940	19166	PROJECTION SET, GM FLIGHT CONTROL, TRAINING BVM	EA	1
						CABLE, ELECTRICAL 3 COND, 5 M LG (GD 940) (FOR PARTS SEE FG 02901) BVM	EA	1

SECTION II

REPAIR PARTS LIST

TM 9-6920-461-20P

(1) ILLUSTRATION		(2)	(3)	(4)	(5)	(6) DESCRIPTION	(7)	(8)
(a) FIG NO.	(b) ITEM NO.	SMR CODE	FEDERAL STOCK NUMBER	PART NUMBER	FSCM	UOC	U/M	QTY INC IN UNIT
2	10	PAOHH	6920-00-960-8441	338	19166	CABLE, ELECTRICAL 3 COND, 4 M LG (774.237) (FOR PARTS SEE FG 3280) BVM	EA	1
2	13	PAOHH	6920-00-961-1220	337	19166	CABLE, ELECTRICAL 19 COND. 4 M LG (774.232) BVM	EA	1
3	1	PAOHH	1430-00-963-0412	810-143	09095	GROUP 0031 STICK, CONTROL, AIR 810-149 (09095) STICK, MODIFIED CONTROL (FOR PARTS SEE FG 0033)	EA	1
5	3	PAOZZ	6923-00-190-1168	100223B4	18876	GROUP 0050 COMPUTER, TYPE CS.6 774-228 (09095)	EA	2
5	20	PAOZZ	6920-00-190-1165	10022387	18876	WASHER S, MU2.5 ,RONDELLE	EA	4
5	26	PAOZZ	6920-00-195-0186	439	19166	WASHER S, MU5, RONDELLE ACIER, XC18, CADMIC BICHROMATE SCREW SP (GD 439)	EA	8
5	29	PAOZZ	6920-00-190-1167	10022385	18876	WASHER S. MU3, RONDELLE ACIER, XC18, CADMIC BICHROMATE	EA	10
5	60	PAOZZ	6920-00-191-0771	8400-14	09095	CAP, COMPLETE (K3)	EA	1
5	65	PAOZZ	6240-00-155-7836	MS25237-327	96906	LAMP, INCANDESCENT 28 V.0.04 AMP,1C-21 TUN-FIL. MIDGET FLGD BASE, T-1-3/4 BULB ,CLEAR ,WHITE LIGHT, 1,000 HR RATED LIFE, 5/8 LG	EA	2
5	68	PAOZZ	6920-00-021-3359	818	19166	CAP, COMPLETE (K2) (GD 818)	EA	1
5	74	PAOZZ	6920-00-191-3718	814	19166	CAP, COMPLETE (K1)I	EA	1
5	79	PAOZZ	6920-00-015-9681	412	19166	DIAL W/KNOB (GD 412)	EA	2
5	93	PAOZZ	6920-00-759-0575	10022371	18876	WASHER	EA	18
5	94	PAOZZ	5355-00-017-2559	10022737	18876	KNOB, CONTROL SPOT BRILLIANCE (STOCKLI 14JF)	EA	1
5	94	PAOZZ	6920-00-015-9682	10173241	18876	KNOB, SWITCH POINTED (STOCKLI 14ME) GROUP 0220 OPTICAL UNIT 11-100 (19166)	EA	2
23	22	PAOZZ	6920-00-317-2561	554	19166	WASHER SP (GD 554) BVL	EA	1
23	32	PAOZZ	6920-00-960-8460	571	19166	CAP, EYEPiece (GD 571) BVL	EA	1
23	51	PAOZZ	6920-00-960-8458	247	19166	LAMP. SPECIAL 24 V,1.5 AMP (GD 247) BVL	EA	1
23	52	PAOZZ	6920-00-190-1169	10022383	18876	WASHER S, M4, RONDELLE ACIER, XC8. TRAITE PENTRATE BVL	EA	2
23	55	PAOZZ	6920-00-015-6322	558	19166	WASHER INS (GD558) BVL	EA	2
23	58	PAOZZ	6920-00-190-1170	10022382	18876	WASHER S, M3, RONDELLE ACIER, XC8 TRAITE PENTRATE BVL	EA	2
23	60	PAOZZ	6920-00-190-1174	10022378	18876	WASHER BR, M2, RONDELLE, LAITON BVL	EA	1
23	60	PAOZZ	6920-00-015-6321	559	19166	WASHER INS (GD 559) BVL	EA	1

SECTION II

REPAIR PARTS LIST

TM 9-6920-461-20P

(1) ILLUSTRATION		(2)	(3)	(4)	(5)	(6) DESCRIPTION	(7)	(8)
(a) FIG NO.	(b) ITEM NO.	SMR CODE	FEDERAL STOCK NUMBER	PART NUMBER	FSCM	UOC	U/M	QTY INC IN UNIT
23	61	PAOZZ	6920-00-015-9538	548	19166	INSULATOR (GD 548) BVL	EA	1
23	64	PAOZZ	6920-00-015-9537	550	19166	INSULATOR (GD 550) BVL	EA	1
24	32	PAOZZ	6923-00-190-9665	BM45	12562	GROUP 0230 HEAD, ELECTRICAL AND MECHANICAL, DX-43 12-000 (19166) CAP BVL	EA	1
25	2	PAOZZ	6920-33-015-9757	10022373	18876	GROUP 0240 BASE, OPTICAL UNIT. DX-43 300 (19166)	EA	12
25	4	PAOZZ	6920-00-960-8462	680	19166	WASHER, LOCK DE5, RONDELLE, EVENTAIL BVL	EA	1
25	8	PAOZZ	6920-30-960-8461	681	19166	SUPPORT, SHOCKMOUNT HARDNESS 45 (GD 680) BVL	EA	1
25	8	PAOZZ	6920-30-960-8461	681	19166	SUPPORT, SHOCKMOUNT HARDNESS 75 (GD 681) BVL	EA	2
26	4	PAOZZ	5310-00-015-9755	10022374	18876	GROUP 0250 PLATFORM, MOVABLE, TYPE PS-2 13-400 (19166)	EA	2
26	8	PAOZZ	6920-00-015-9773	8P6	21781	WASHER. LOCK DE5, RONDELLE, EVENTAIL BVL	EA	3
26	9	PAOZZ	6920-00-190-1172	10022380	18876	NUT, LOCK NYLON (SIMMONDS 8P6) BVL	EA	3
26	13	PAOZZ	6920-00-960-8463	299	19166	WASHER S, M8, RONDELLE ACIER, XC18, CADMIC BICHROMATE BVL	EA	3
26	14	PAOZZ	6920-00-015-9525	311	19166	HINGE, SHOCKMOUNT (GD 299) BVL	EA	2
26	15	PAOZZ	6920-00-960-8464	312	19166	WASHER (GD 311) BVL	EA	1
26	16	PAOZZ	6920-00-015-9743	10022329	18876	WASHER 12.2 MM ID, 38 MM OD, 2 MM THK, FERODO (GD 312) BVL	EA	2
26	16	PAOZZ	6920-00-015-9743	10022329	18876	SCREW, SET HEX-SOCKET, CUP-PT, 4 X 6, BLACK (BTR E27118) BVL	EA	3
27	1	PAOZZ	6920-00-015-6427	10022342	18876	GROUP 0260 TRIPOD, TYPE TS1 13-100 (19166)	EA	8
27	3	PAOZZ	6920-00-190-1172	10022383	18876	SCREW S, F 4 X 10 BVL	EA	8
27	5	PAOZZ	6920-00-190-1173	10022379	18876	WASHER S, M8, RONDELLE ACIER, XC18, CADMIC BICHROMATE BVL	EA	1
27	7	PAOZZ	6920-00-015-9754	10022376	18876	WASHER S, M5, RONDELLE ACIER, XC18, CADMIC BICHROMATE BVL	EA	2
27	11	PAOZZ	5310-00-015-9755	10022374	18876	WASHER K39.6 X 26.5, RONDELLE (SCHNOOU 6203) BVL	EA	13
27	11	PAOZZ	5310-00-015-9755	10022374	18876	WASHER, LOCK DE5, RONDELLE, EVENTAIL BVL	EA	3
						GROUP 0280		

SECTION II

REPAIR PARTS LIST

TM 9-6920-461-20P

(1) ILLUSTRATION		(2)	(3)	(4)	(5)	(6)	(7)	(8)
(a) FIG NO.	(b) ITEM NO.	SMR CODE	FEDERAL STOCK NUMBER	PART NUMBER	FSCM	DESCRIPTION UOC	U/M	QTY INC IN UNIT
28	2	PAOZZ	6920-00-015-6465	8082	18834	CABLE, ELECTRICAL 338 (19166)	EA	1
28	3	PAOZZ	6920-00-015-9797	BFM1	12562	CAP (SOURIAU 8082) CAP (SOURIAU BFM1) GROUP 0290	EA	1
29	1	PAOZZ	5935-00-280-2381	WC596D24	81348	CABLE, ELECTRICAL 940 (19166)		
29	2	PAOZZ	6920-00-015-9634	BFF1	12562	CONNECTOR, PLUG .ELECTRICAL 3 MALE CONTACTS, PLASTIC DIELECTRIC, STGHT SHAPE CAP (SOCAPEX BFF1) GROUP 0300	EA EA	1 1
30	7	PAOZZ	6920-00-960-8477	358	19166	POWER SUPPLY, REGULATED, GC-24 1165 (19166)		
30	8	PAOZZ	6920-00-016-2607	10022657	18876	FUSE, SLOBLO 2 AMP, 5 X 20 MM (GD 358) (F1)	BVL	EA 1
30	11	PAOZZ	6920-00-015-9798	10022656	18876	CAP AIRTIGHT (SOCAPEX BEF1) CAP AIRTIGHT (SOCAPEX BEM1) GROUP 0330	BVL BVL	EA EA 1
32	42	PAOZZ	6920-00-015-9599	1191	19166	PROJECTOR UNIT 22010 (19166)		
32	51	PAOZZ	6920-00-960-8477	358	19166	LAMP 160 V,10 H (GC 1191) FUSE, SLOBLO 2 AMP. 5 X 20 NM (GD 358) (F1)	BVM	EA 1
32	66	PAOZZ	6920-00-960-8433	204	19166	LENS 1.5 DIOPTERS, 40 MM DIA (GD 204)	BVM	EA 1
32	73	PAOZZ	6920-00-015-6411	133	19166	NEEDLE (GD 133) GROUP 0340	BVM	EA 2
33	21	PAOZZ	6920-00-960-8458	247	19166	SUPPORT 747 (19166) LAMP, SPECIAL 24 V,1.5 AMP (GD 247)	BVM	EA 1

SECTION IV. ILLUSTRATIONS

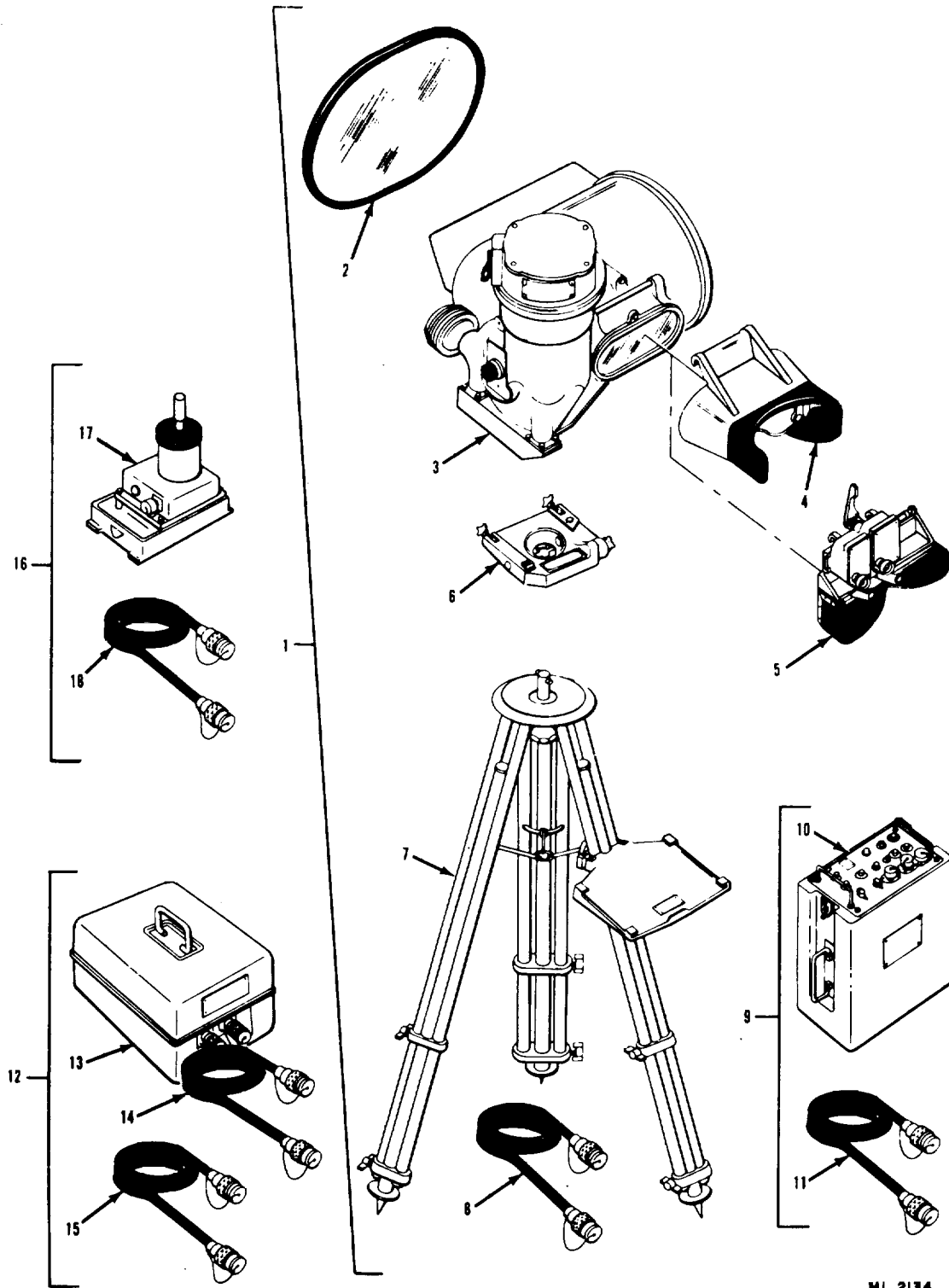

MI 2134

Figure 1. (Group 0010) Training set, guided missile flight control (DX-43) (M-22) (10173200)

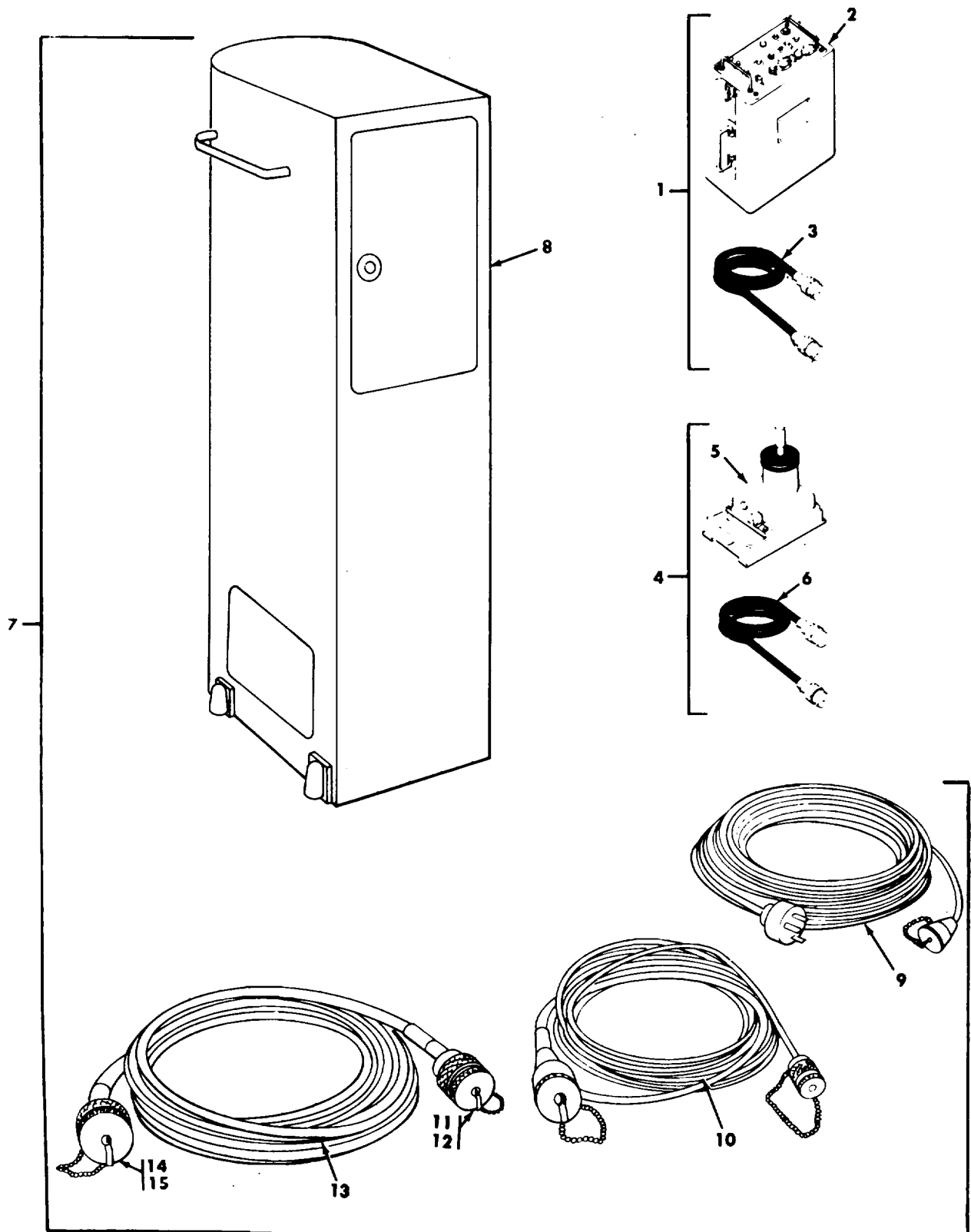

MI 3352

Figure 2. (Group 0020) Training set, guided missile flight control (X-44) (M-22) (10173201)

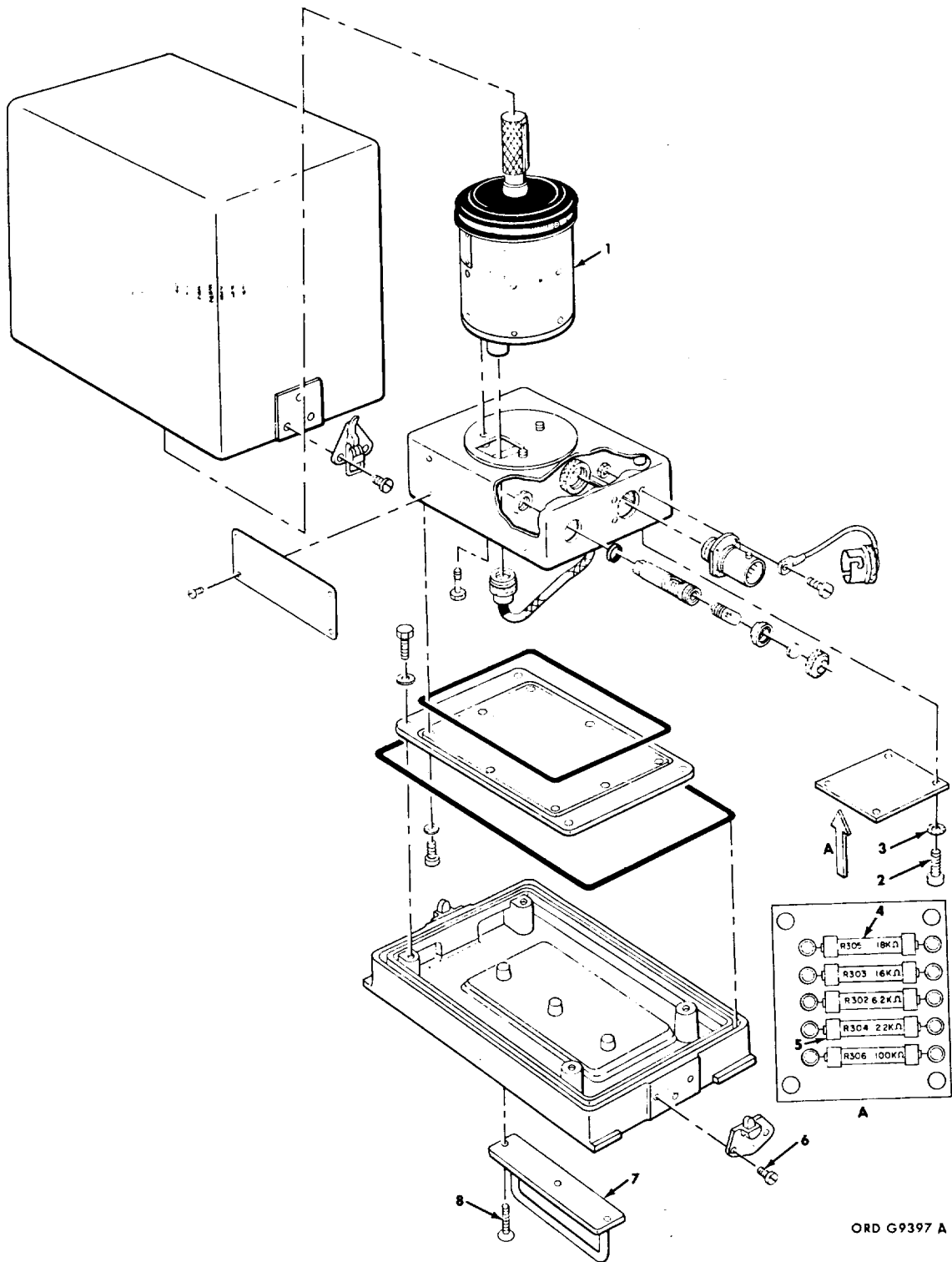
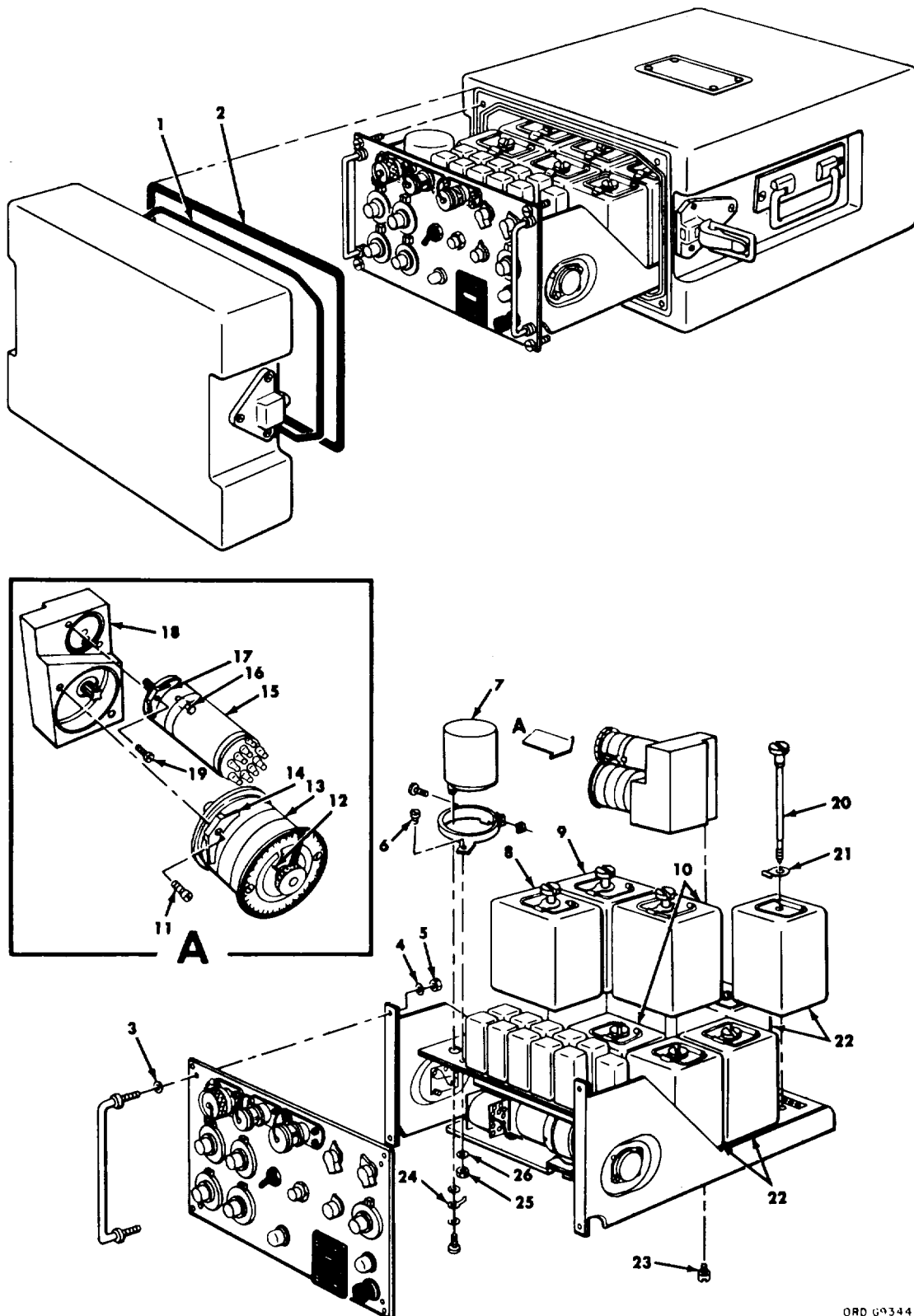

Figure 3. (Group 0031) Stick, control, air (810-149)



ORD 69344A

Figure 5. (Group 0050) Computer, type CS.6 (774-228) - sheet 1 of 4

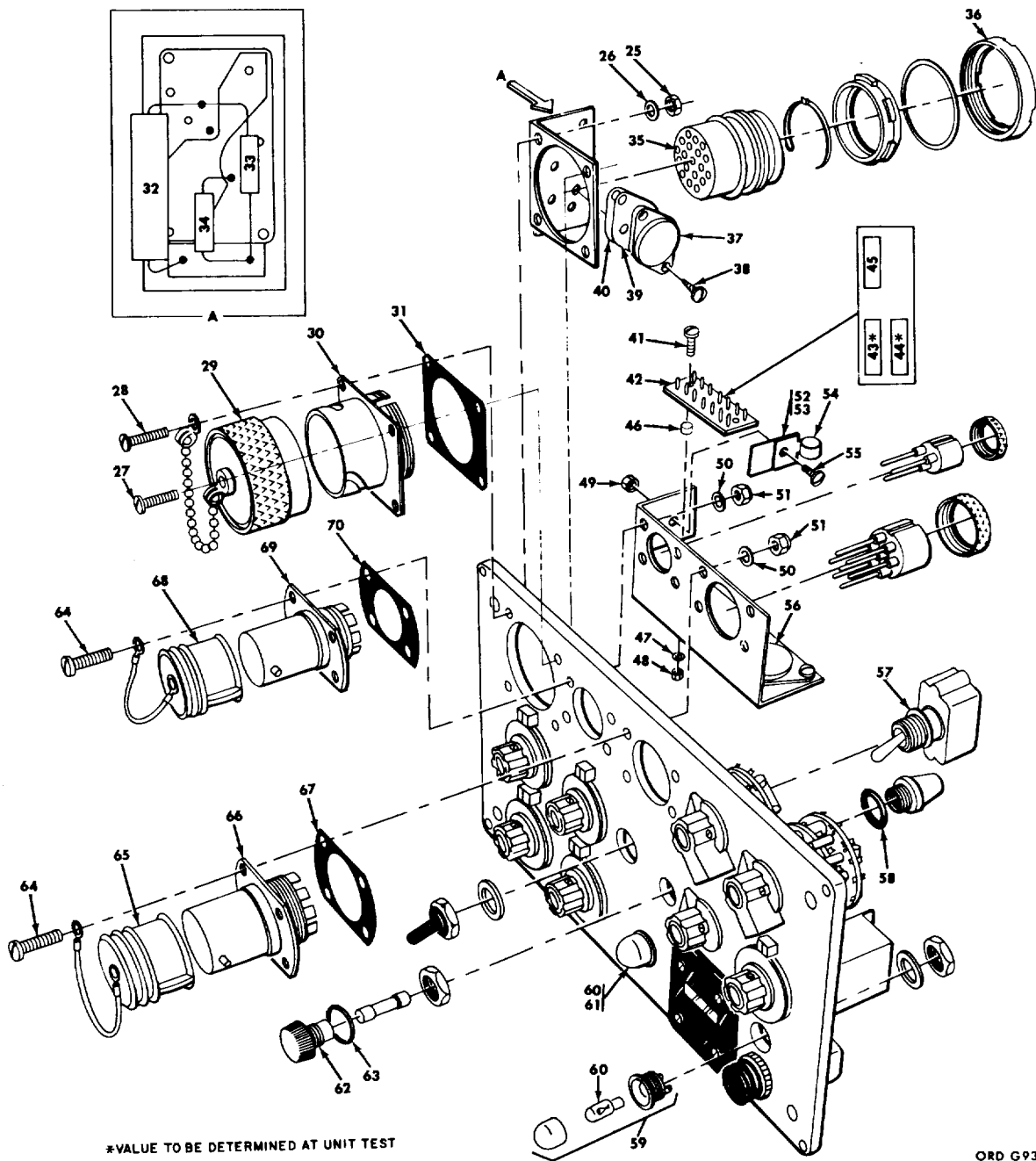
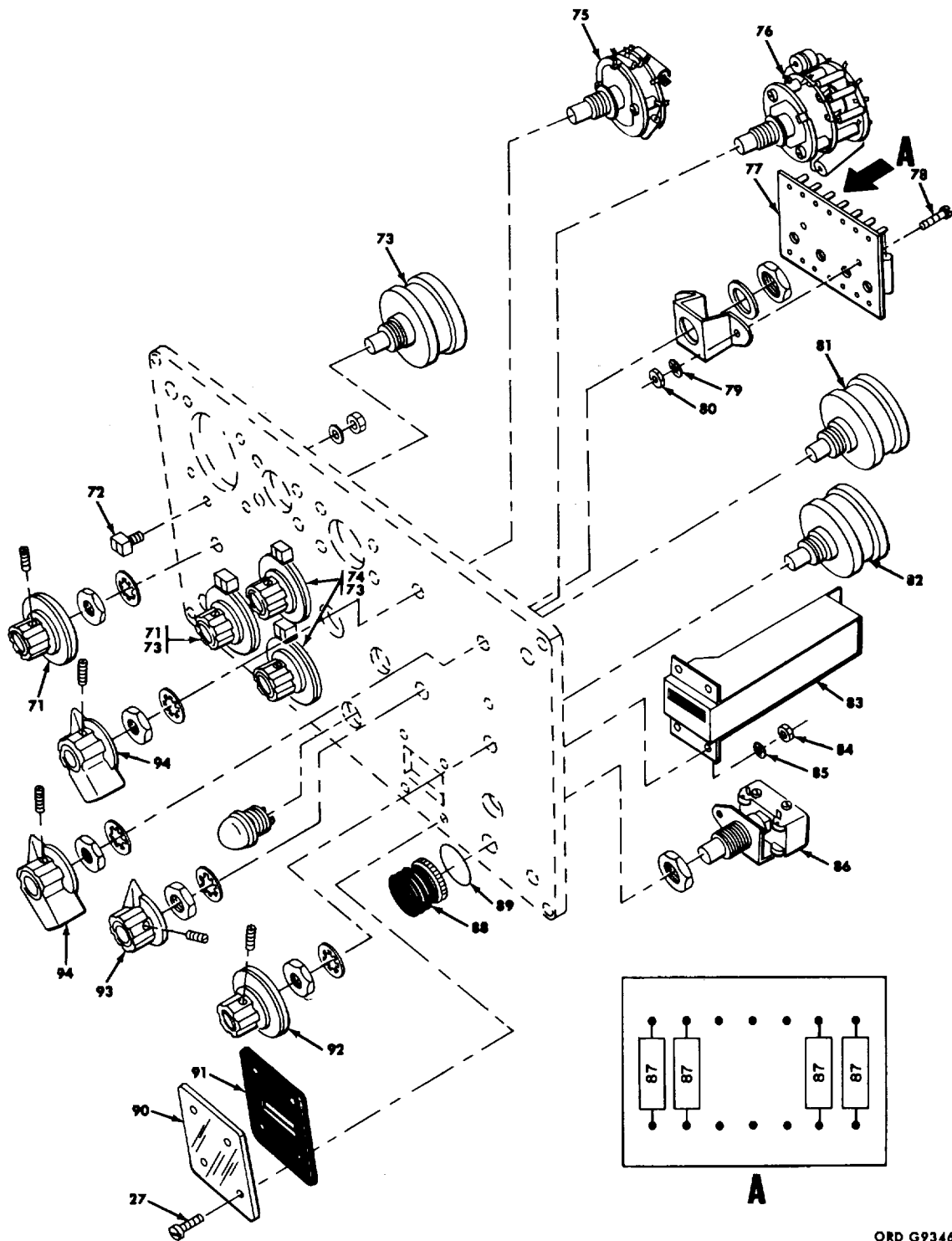
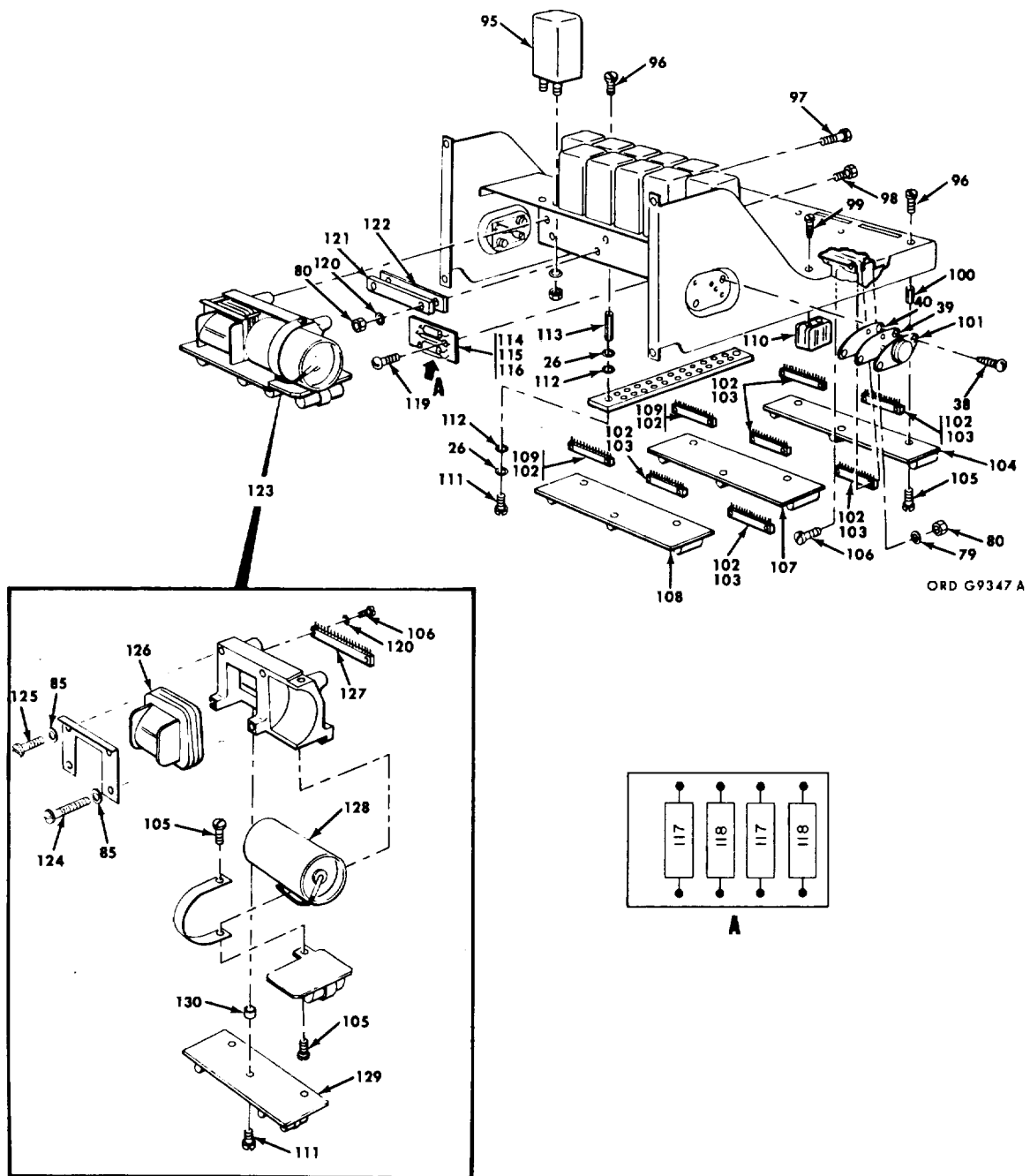

Figure 5. (Group 0050) Computer, type CS.6 (774-228) - sheet 2 of 4



ORD G9346 A

Figure 5. (Group 0050) Computer, type CS.6 (774-228) - sheet 3 of 4



ORD G9347 A

Figure 5. (Group 0050) Computer, type CS.6 (774-228) - sheet 4 of 4

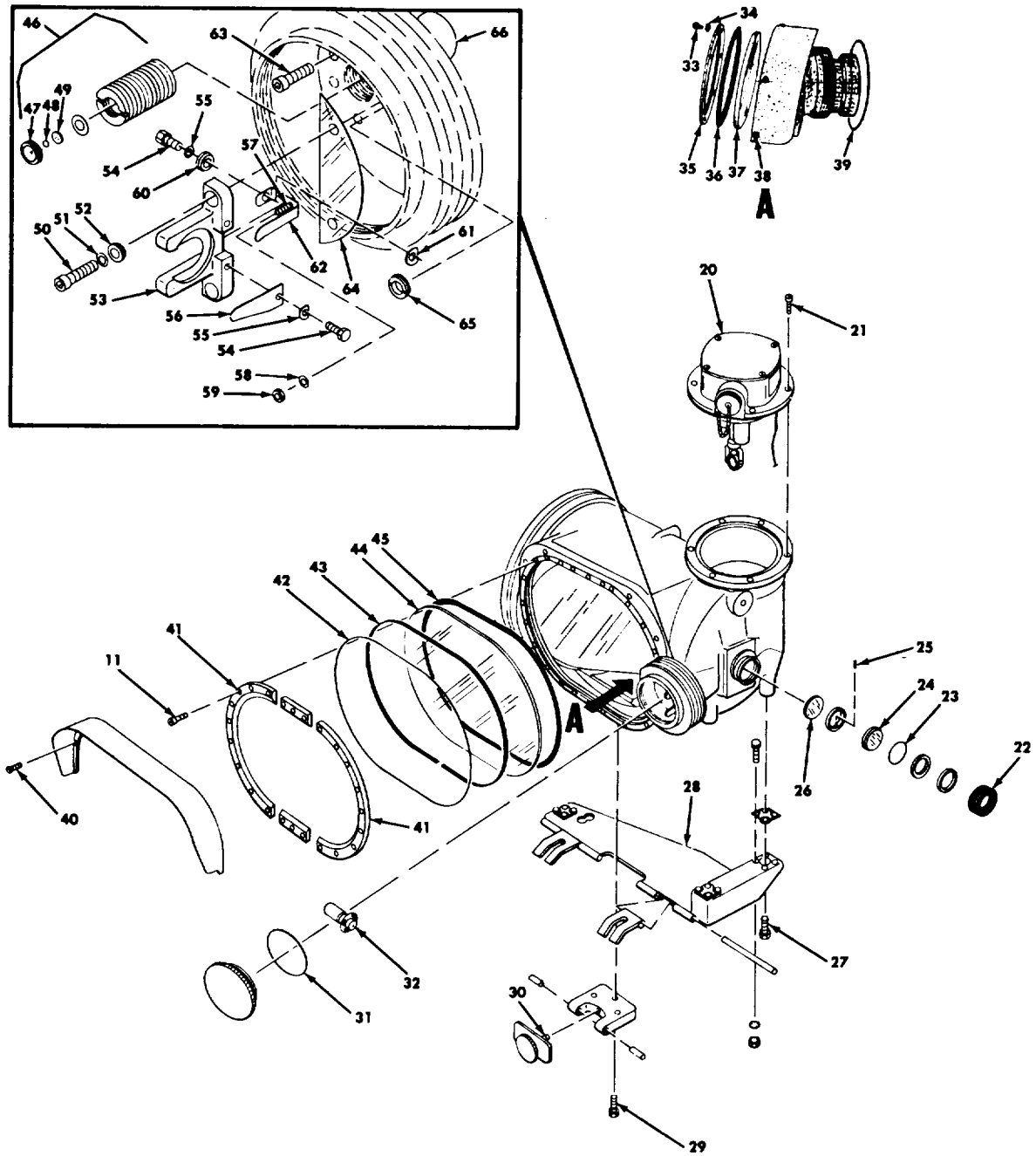
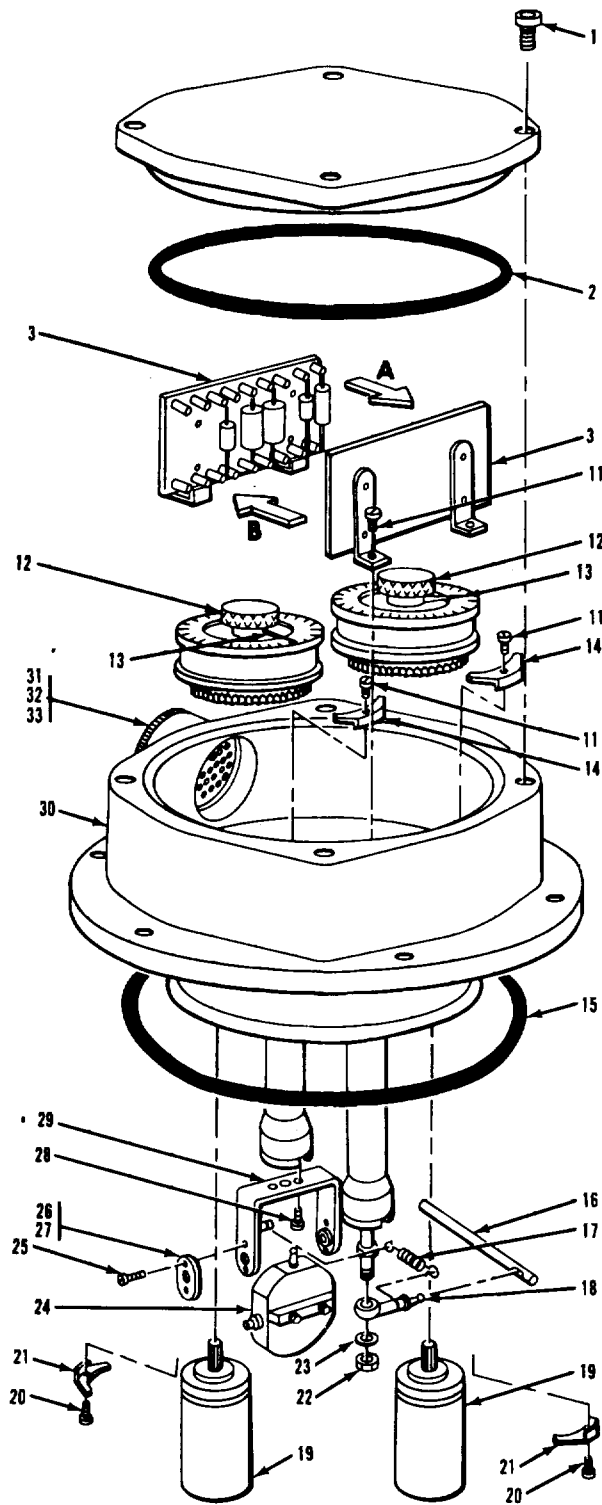
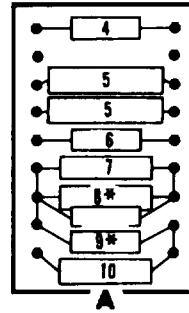

Figure 23. (Group 0220) Optical unit (11-100)

ORD G9335 B



TERMINAL STRIP J2



TERMINAL STRIP J1

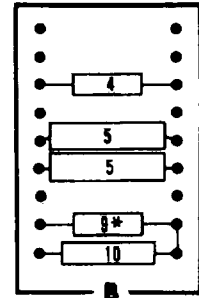

* VALUE TO BE DETERMINED AT UNIT TEST

ORD G9629A

Figure 24. (Group 0230) Head, electrical and mechanical, DX-43 (12-000)

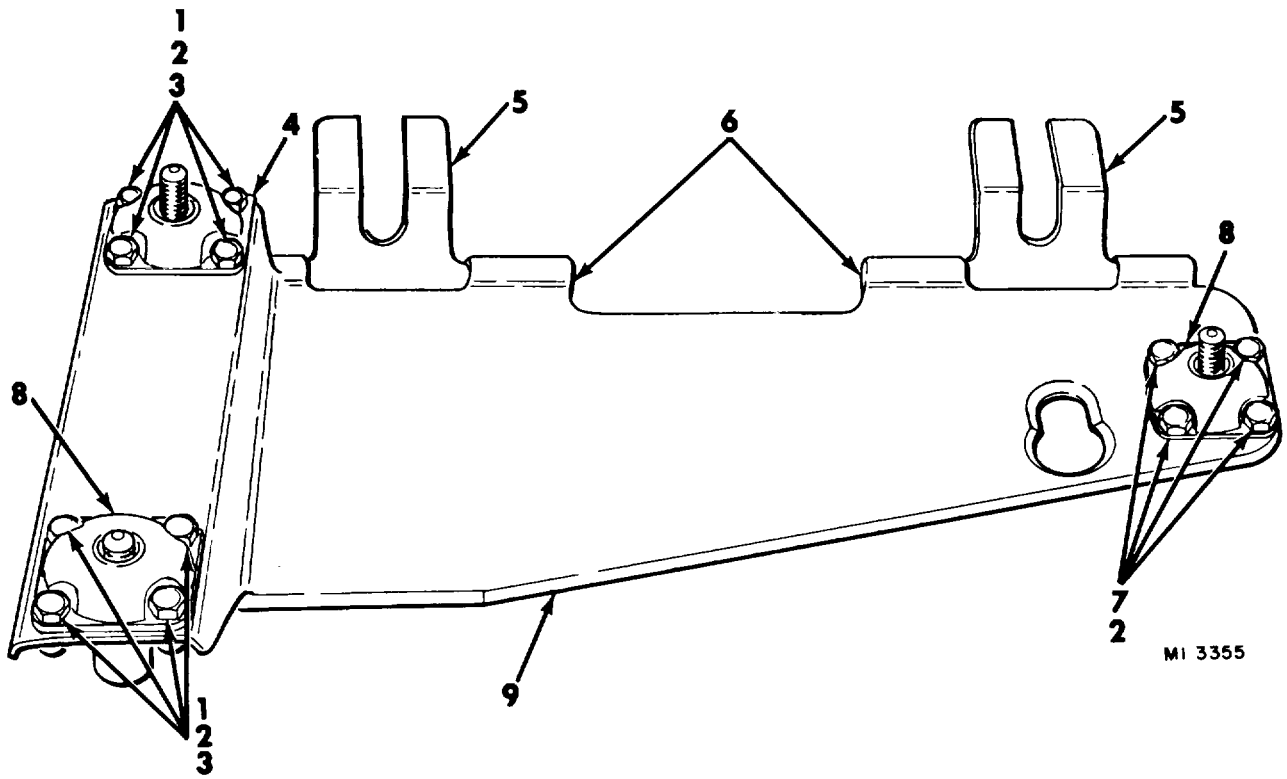
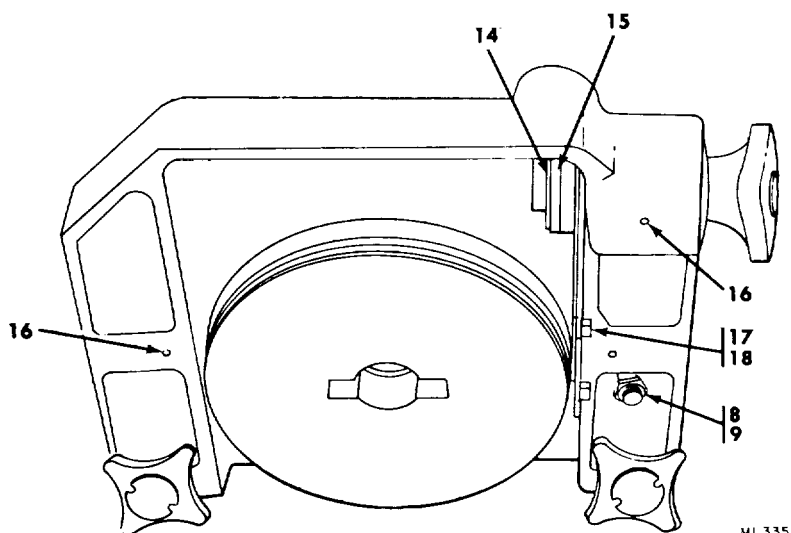
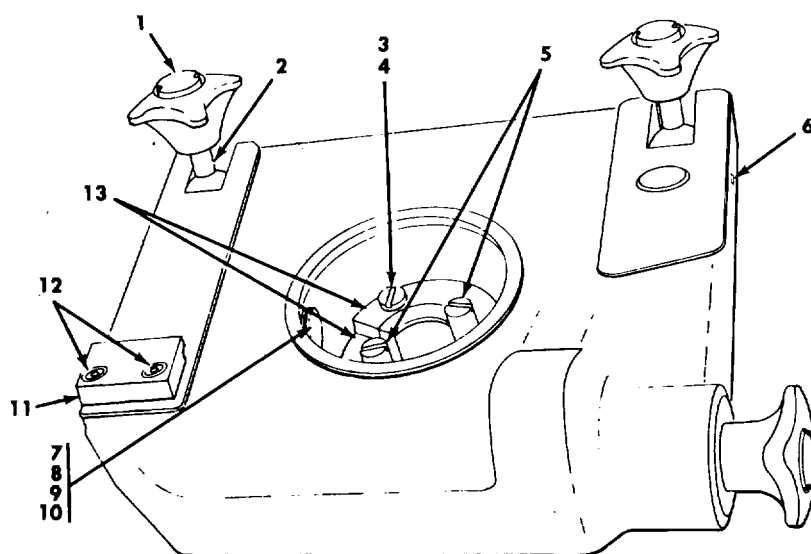

Figure 25. (Group 0240) Base, optical unit, DX-43 (300)



MI 335F

Figure 26. (Group 0250) Platform, movable, type PS-2 (13-400)

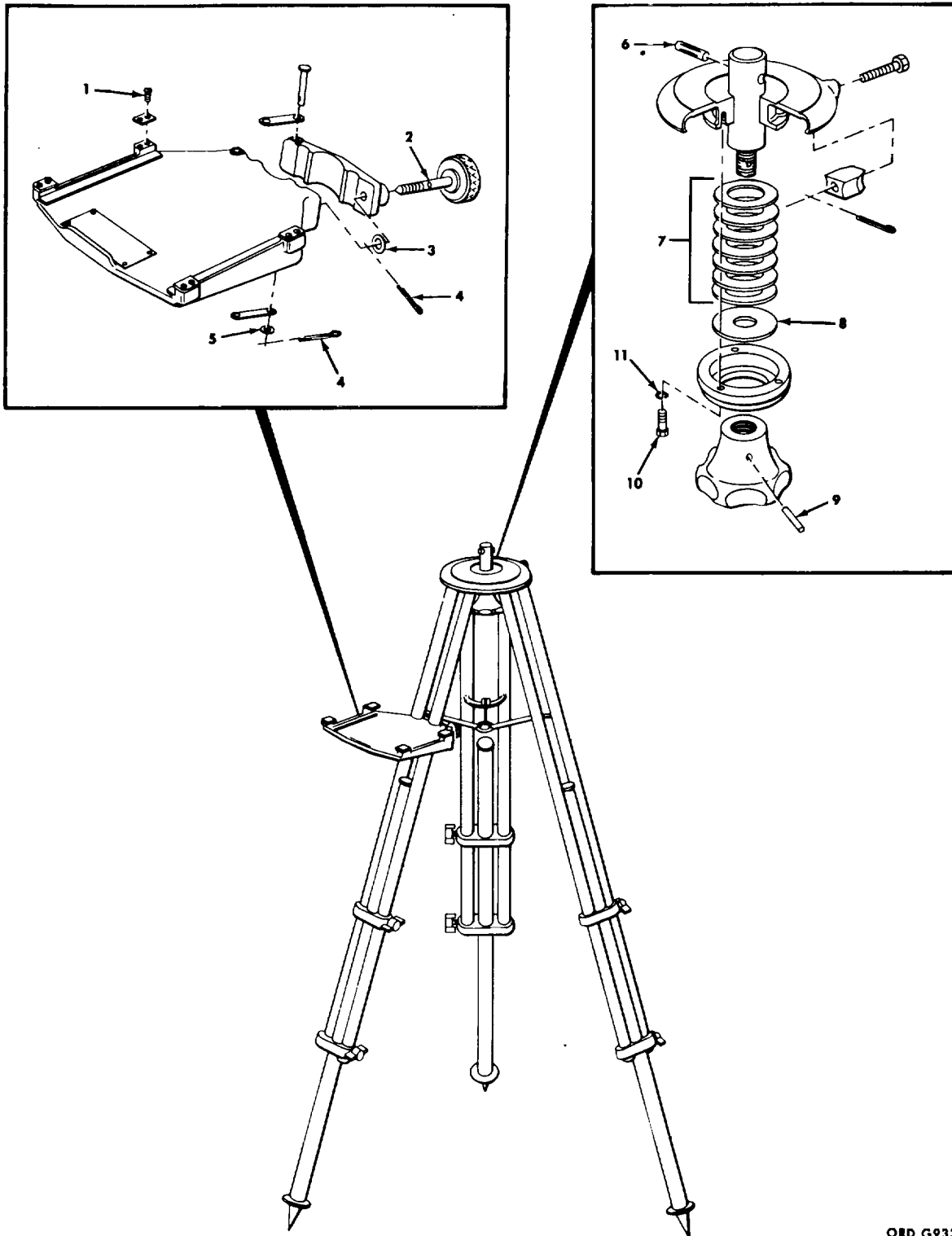
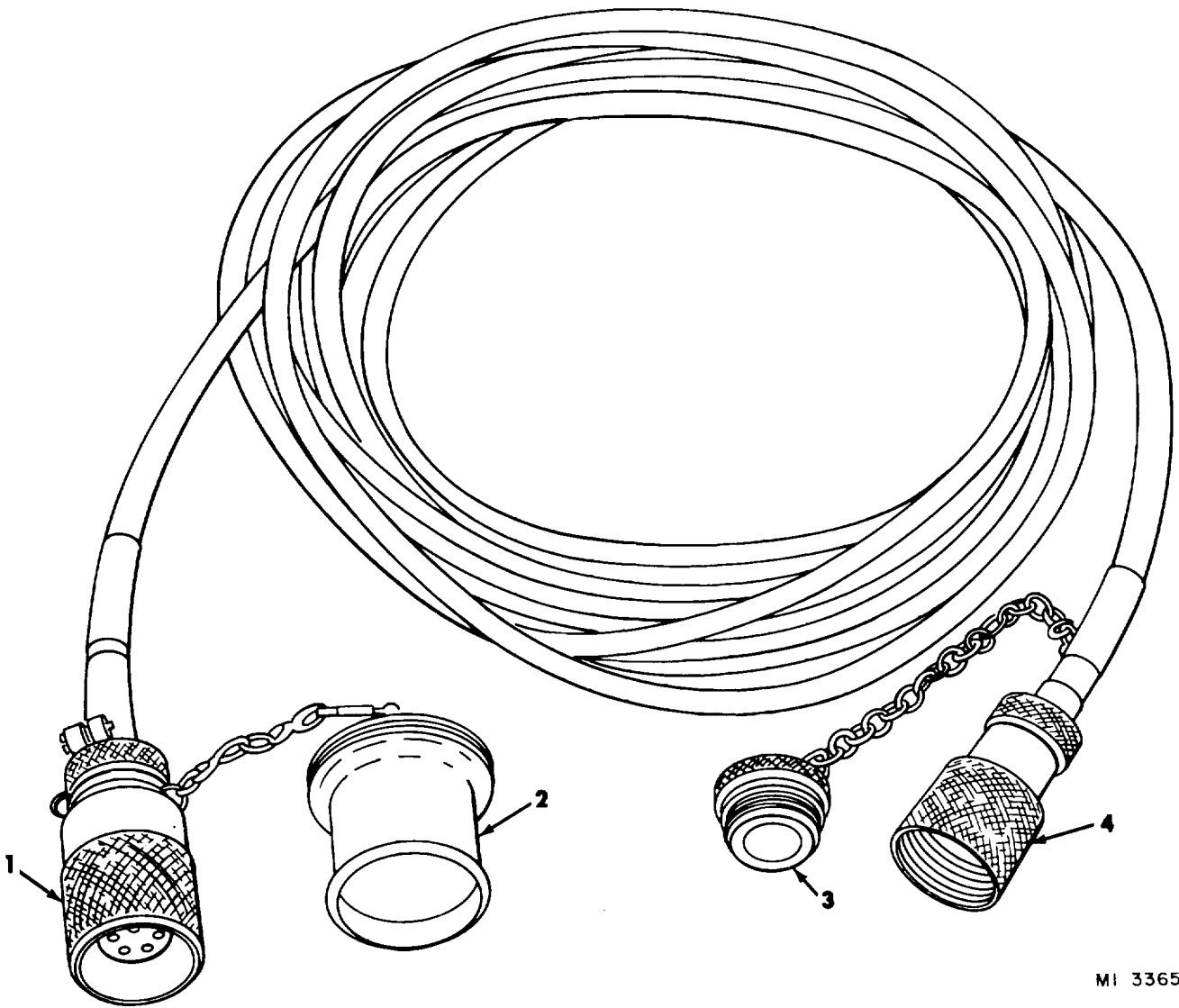

Figure 27. (Group 0260) Tripod, type TS1 (13-100)

ORD G9338A



MI 3365

Figure 28. (Group 0280) Cable, electrical (338)

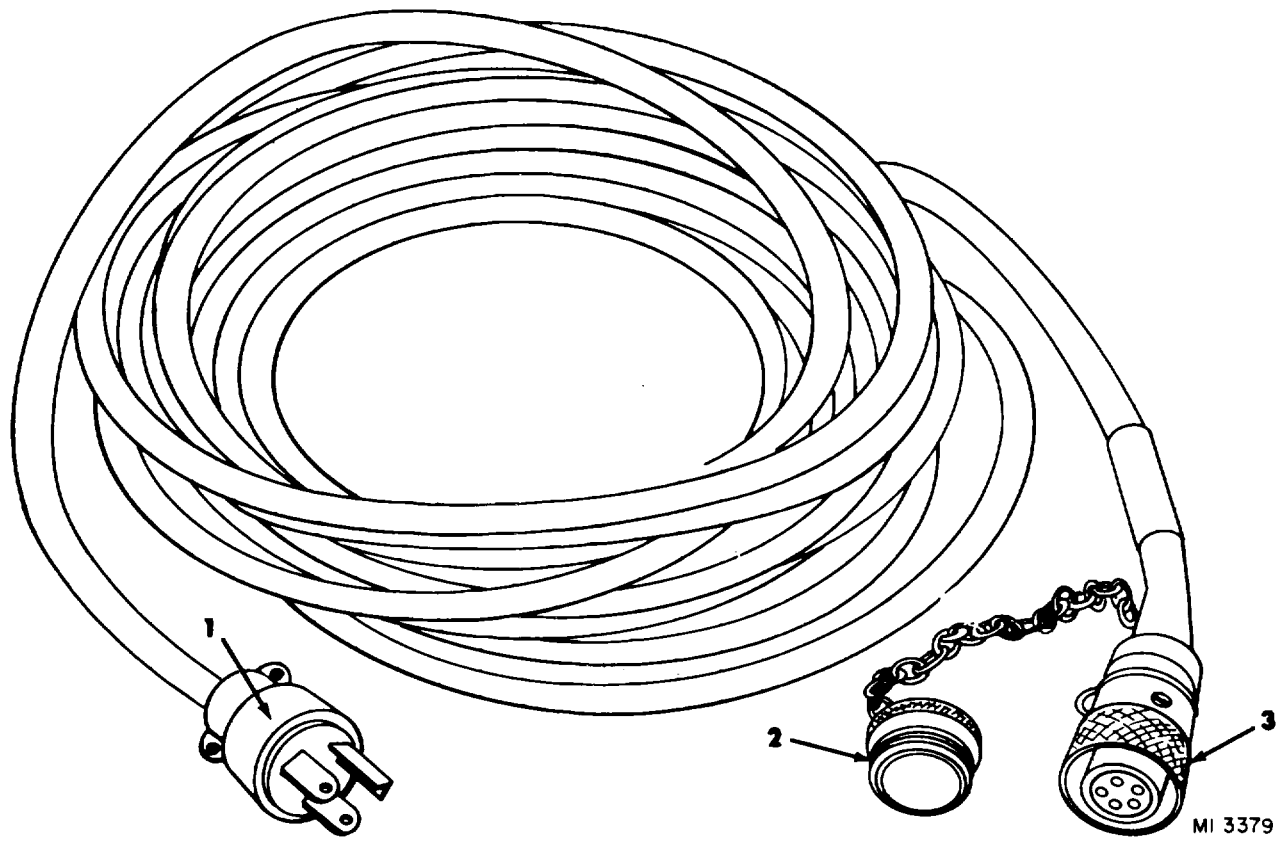

Figure 29. (Group 0290) Cable, electrical (940)

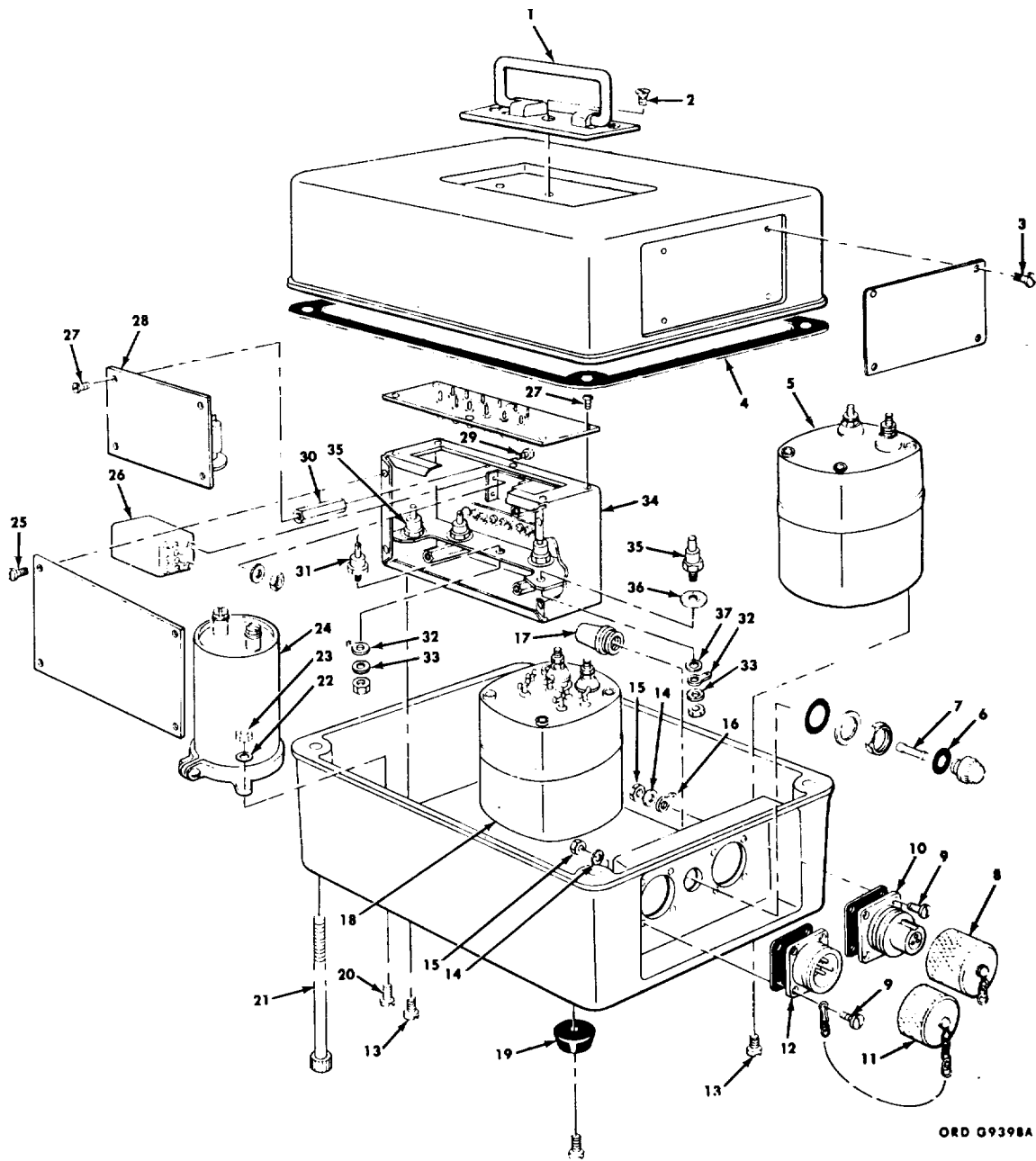
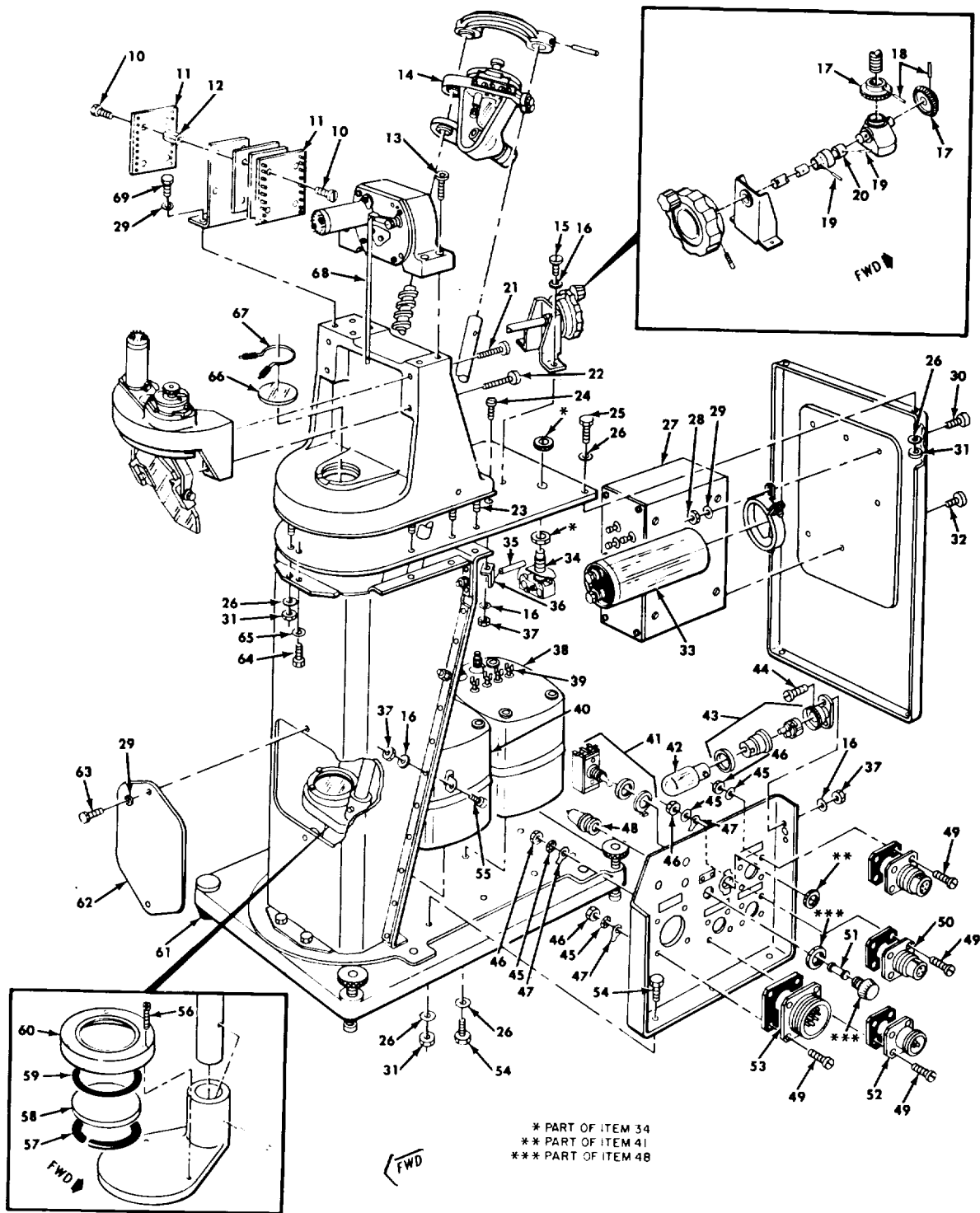

Figure 30. (Group 0300) Power supply, regulated, GC-24 (1165)



ORD G9375A

Figure 32. (Group 0330) Projector unit (22010) - sheet 1 of 2

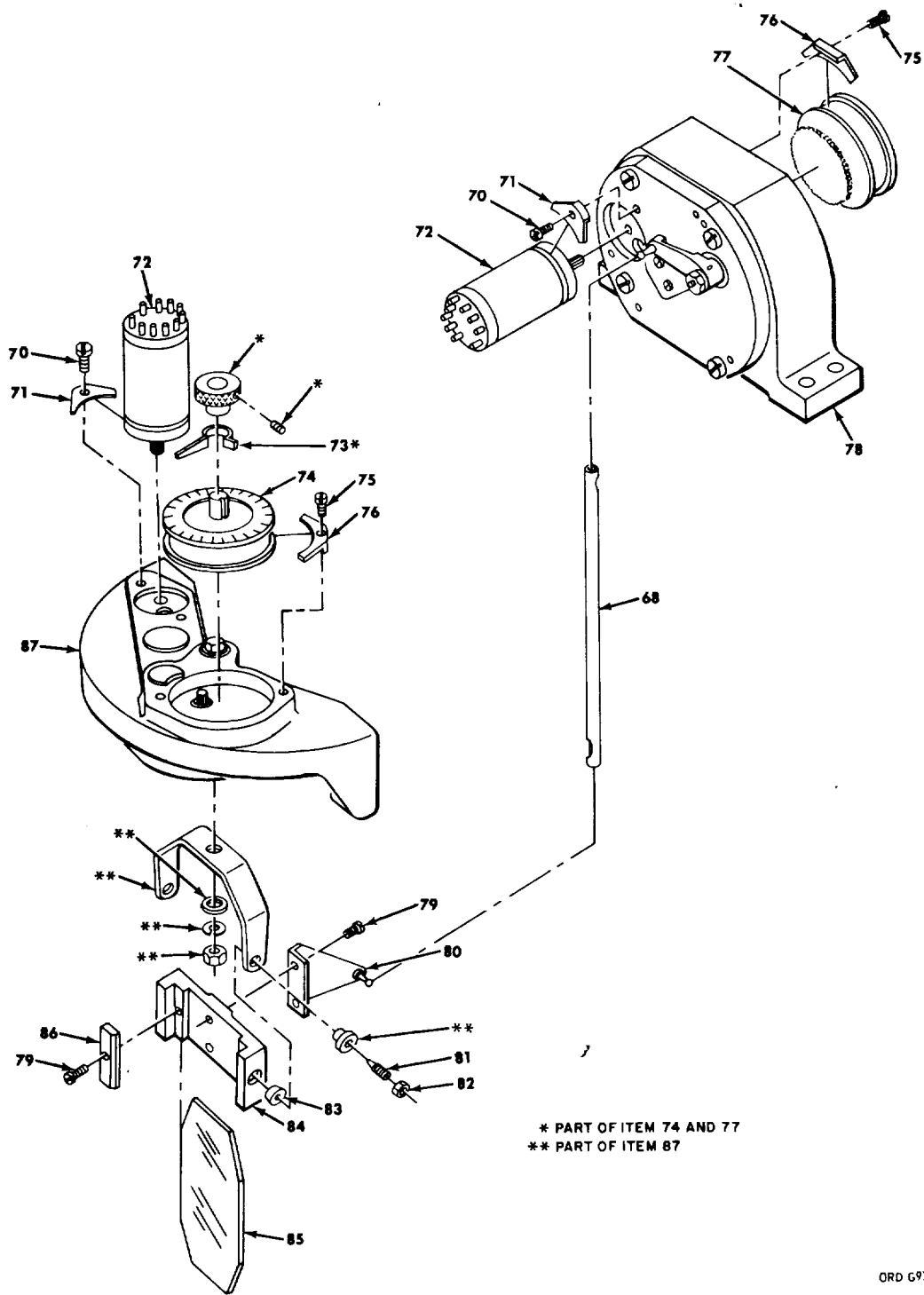
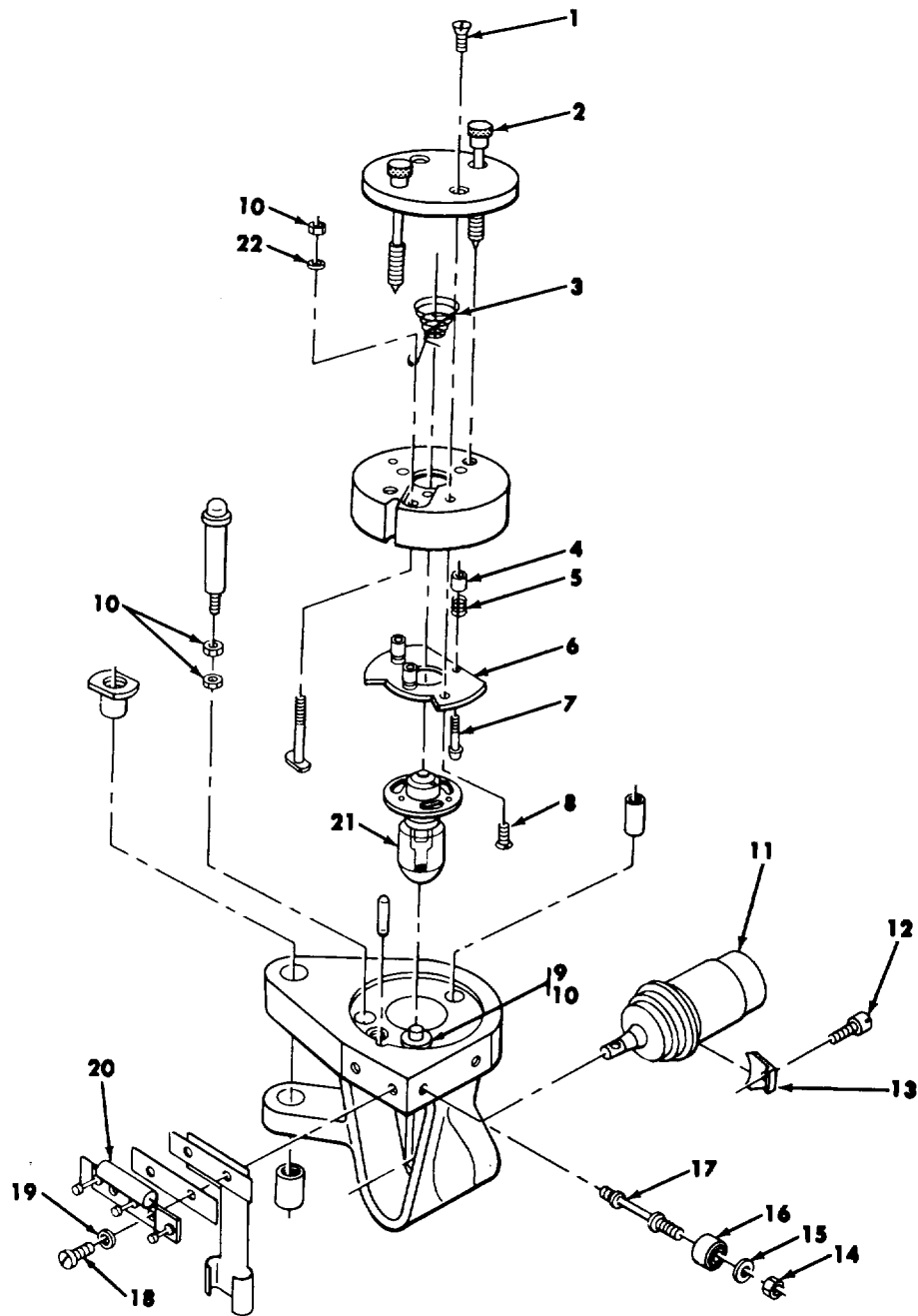

Figure 32. (Group 0330) Projector unit (22010) - sheet 2 of 2



ORD G9372A

Figure 33. (Group 0340) Support (747)

SECTION V

TM 9-6920-461-20P

NATIONAL STOCK NUMBER AND PART NUMBER INDEX

STOCK NUMBER	FIG.	ITEM	STOCK NUMBER	FIG.	ITEM
6923-00-015-6321	23	60	5935-00-280-2381	29	1
6923-00-015-6322	23	52	6920-00-759-0575	5	79
6923-00-015-6411	32	73	1430-00-887-9102	1	18
6923-00-015-6427	27	1	1430-00-887-9102	2	6
6920-00-015-6465	28	2	6920-00-960-8433	32	66
6923-00-015-9525	26	14	6920-00-960-8438	1	7
6920-00-015-9537	23	64	6920-00-960-8439	1	17
6920-00-015-9538	23	61	6920-00-960-8439	2	5
6920-00-015-9599	32	42	6920-00-960-8440	1	15
6920-30-015-9634	29	2	6920-00-960-8440	2	9
6920-00-015-9681	5	74	6920-00-960-8441	1	14
6920-00-015-9682	5	94	6920-00-960-8441	2	10
6920-00-015-9743	26	16	6920-00-960-8442	1	13
6920-00-015-9754	27	7	6920-00-960-8453	1	16
5310-00-015-9755	26	4	6920-00-960-8453	2	4
5310-00-015-9755	27	11	6920-00-960-8454	1	9
6920-00-015-9757	25	2	6920-00-960-8454	2	1
6920-00-015-9773	26	8	6920-00-960-8455	1	12
6920-00-015-5797	28	3	6920-00-960-8457	1	2
6920-00-315-9798	30	11	6920-00-960-8458	23	32
6920-00-016-2607	30	8	6920-00-960-8458	33	21
5355-00-017-2559	5	93	6920-00-960-8459	1	8
6920-00-017-2561			6920-00-960-8460	23	22
6920-00-021-3359	5	65	6920-00-960-8461	25	8
6240-00-155-7836	5	60	6920-00-960-8462	25	4
6920-00-190-1165	5	3	6920-00-960-8463	26	10
6920-00-193-1167	5	26	6920-00-960-8464	26	15
6920-00-190-1168			6920-00-960-8467	1	6
6920-00-190-1169	23	51	6920-00-960-9468	1	10
6920-00-190-1177	23	55	6920-00-960-8468	2	2
6920-00-190-1173	26	9	6920-00-960-8469	1	11
6920-00-190-1172	27	3	6920-00-960-8469	2	3
6920-00-190-1173	27	5	6920-00-960-8475	1	1
6920-00-190-1174	23	58	6920-00-960-8477	30	7
6920-00-190-9665	24	32	6920-00-960-8477	32	51
6920-00-191-0771	5	29	6920-00-960-8481	2	7
6920-00-191-3718	5	68	6920-00-961-1220	2	13
6920-00-195-0186	5	20	1430-00-963-0412	3	1

PART NUMBER	FSCM	FIG. NO.	ITEM NO.	PART NUMBER	FSCM	FIG. NO.	ITEM NO.
BFF1	12562	29	2	13-100	19166	1	7
BFM1	12562	28	3	13-400	19166	1	6
BM45	12562	24	32	133	19166	32	73
MS25237-327	96036	5	60	23010	19166	2	7
WC596D24	81348	29	1	204	19166	32	66
10-000	19166	1	1	247	19166	23	32
10021921	18876	1	18	247	19166	33	21
10021921	18876	2	6	299	19166	26	10
10022329	18876	26	16	311	19166	26	14
10022342	18876	27	1	312	19166	26	15
10022371	18876	5	79	336	19166	1	8
10022373	18876	25	2	337	19166	2	13
10022374	18876	26	4	338	19166	1	14
10022374	18876	27	11	338	19166	2	10
10022376	18876	27	7	358	19166	30	7
10022378	18876	23	58	358	19166	32	51
10022379	18876	27	5	412	19166	5	74
10022380	18876	26	9	439	19166	5	20
10022383	18876	27	3	507	19166	1	2
10022382	18876	23	55	548	19166	23	61
10022383	18876	23	51	550	19166	23	64
10022384	18876			554	19166		
10022385	18876	5	26	558	19166	23	52
10022387	18876	5	3	559	19166	23	60
10022656	18876	30	11	571	19166	23	22
10022657	18876	30	8	680	19166	25	4
10022737	18876	5	93	681	19166	25	8
10173162	18876	1	11	774-228	09095	1	10
10173162	18876	2	3	774-228	09095	2	2
10173189	18876	1	16	8P6	21781	26	8
10173189	18876	2	4	8082	18834	28	2
10173194	18876	1	9	810-140	09095	3	1
10173194	18876	2	1	810-149	09095	1	17
10173241	18876	5	94	810-149	09095	2	5
1160	19166	1	12	814	19166	5	68
1165	19166	1	13	818	19166	5	65
1191	19166	32	42	8400-14	09095	5	29

SECTION V

TM 9-6920-461-20P

NATIONAL STOCK NUMBER AND PART NUMBER INDEX

PART NUMBER	FSCM	FIG. NO.	ITEM NO.	PART NUMBER	FSCM	FIG. NO.	ITEM NO.
940	19166	1	15	940	19166	2	9

By Order of the Secretary of the Army:

Official:

PAUL T. SMITH
Major General, United States Army
The Adjutant General.

FRED C. WEYAND,
General, United States Army,
Chief of Staff

Distribution:

To be distributed in accordance with DA Form 12-31, (qty rqr block no. 451) organizational maintenance requirements for M-22 missile system

*U. S. GOVERNMENT PRINTING OFFICE: 1976-641-219/165

RECOMMENDED CHANGES TO EQUIPMENT TECHNICAL PUBLICATIONS



THEN... JOT DOWN THE DOPE ABOUT IT ON THIS FORM, CAREFULLY TEAR IT OUT, FOLD IT AND DROP IT IN THE MAIL!

SOMETHING WRONG WITH THIS PUBLICATION?

FROM: (PRINT YOUR UNIT'S COMPLETE ADDRESS)

DATE SENT

PUBLICATION NUMBER

PUBLICATION DATE

PUBLICATION TITLE

BE EXACT... PIN-POINT WHERE IT IS

IN THIS SPACE TELL WHAT IS WRONG AND WHAT SHOULD BE DONE ABOUT IT:

PAGE NO.	PARA-GRAPH	FIGURE NO.	TABLE NO.
----------	------------	------------	-----------

TEAR ALONG PERFORATED LINE

PRINTED NAME, GRADE OR TITLE, AND TELEPHONE NUMBER

SIGN HERE:

DA FORM 2028-2 JUL 79

PREVIOUS EDITIONS ARE OBSOLETE.

P.S.—IF YOUR OUTFIT WANTS TO KNOW ABOUT YOUR RECOMMENDATION MAKE A CARBON COPY OF THIS AND GIVE IT TO YOUR HEADQUARTERS.

